

9m Water Taxi



Principal Particulars

Length overall	9.3	metres
Length waterline	7.9	metres
Moulded beam	3.6	metres
Design draught	0.5	metres

Deadweight

Passengers	12	
Crew	2	
Fuel	880	litres
Maximum deadweight	1.9	tonnes

Performance & Range

Speed	30	knots
Service speed	28	knots

Machinery

Main engines

2 x Volvo AQUP D41DP Diesel Engines

Propulsors

2 x Volvo Dual Propeller Stern Drive Units

Construction

Composite

Builder

Prout Catamarans

Project No

NG214

No Built

5

Year Launched

1996

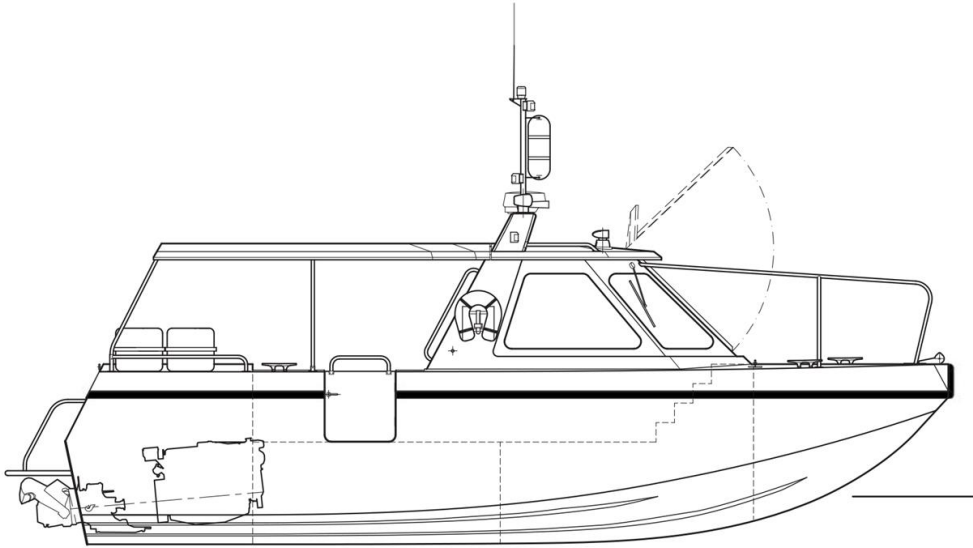

Outboard Profile

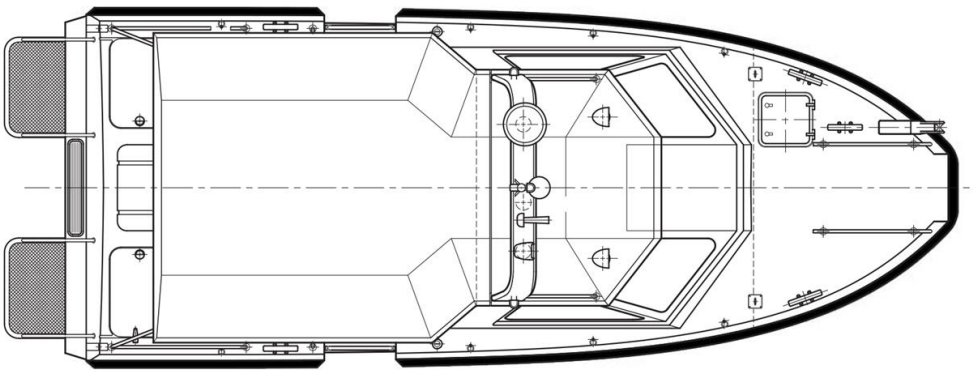

Deck View

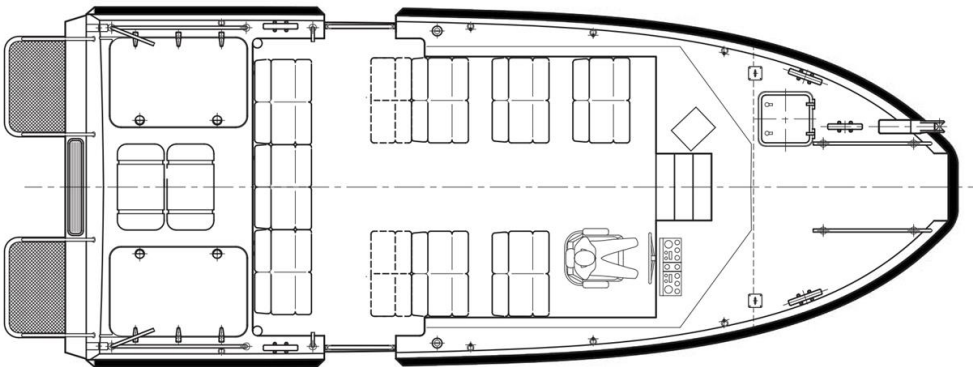

Plan View